

1 TYPICAL CONSTRUCTION JOINT DETAIL
SCALE: NO SCALE

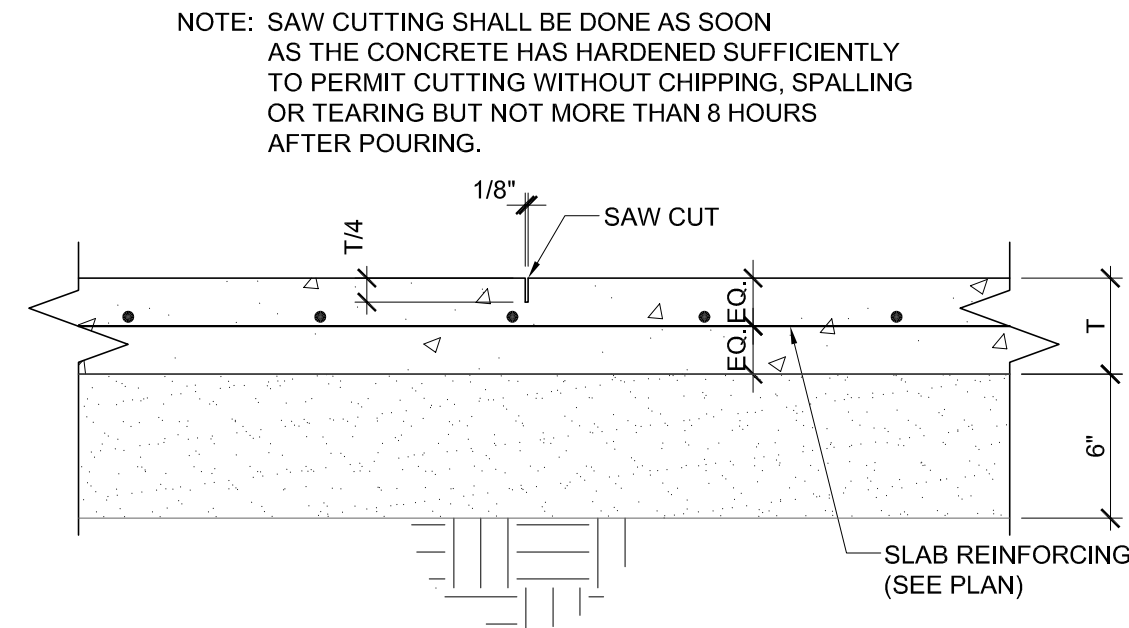

2 TYPICAL CONTROL JOINT DETAIL
SCALE: NO SCALE

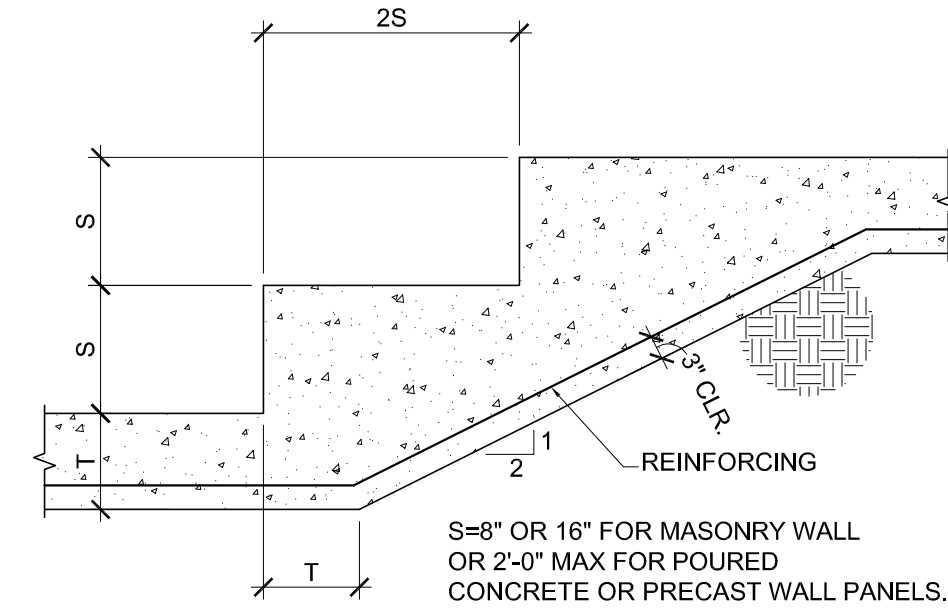

3 TYPICAL STEP FOOTING DETAIL
SCALE: NO SCALE

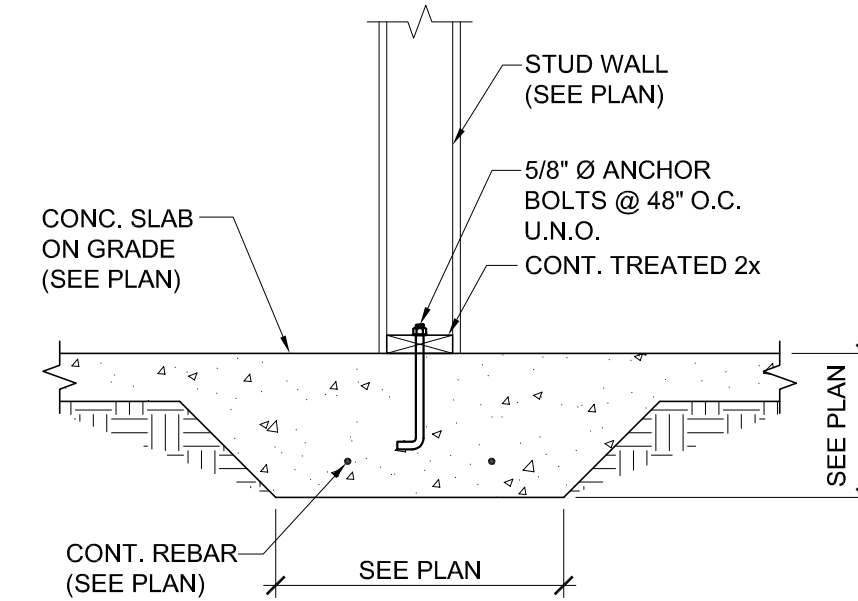

4 THICKENED SLAB FOOTING DETAIL
SCALE: NO SCALE

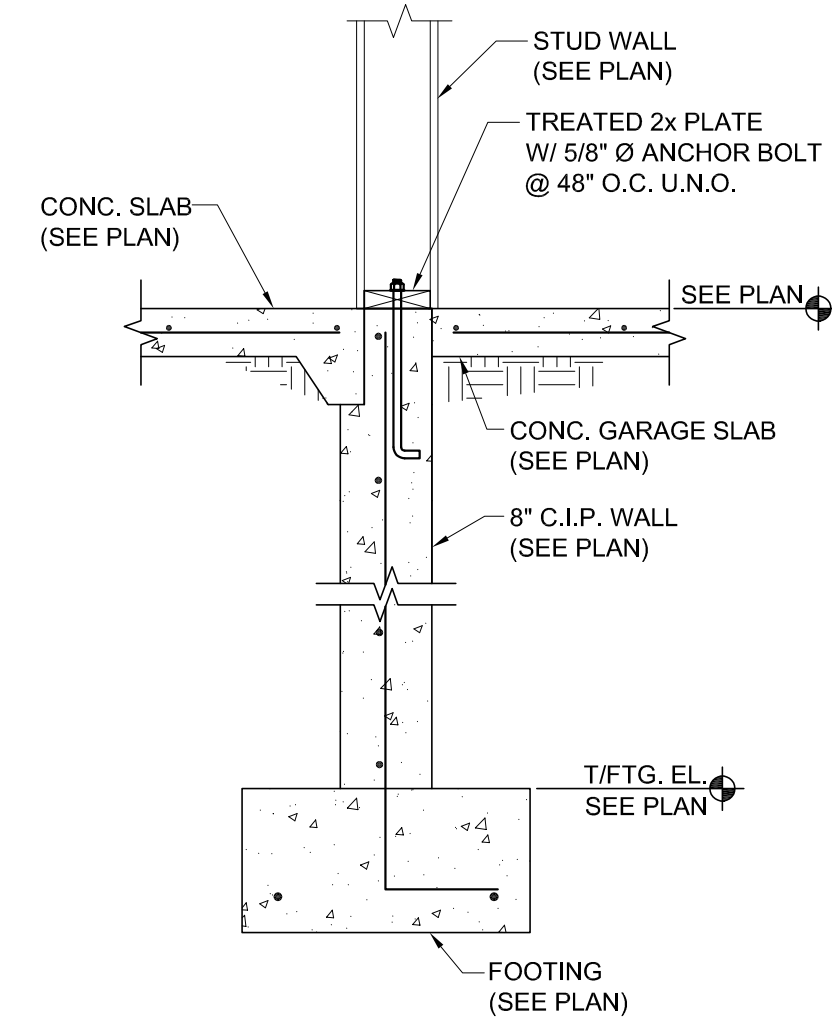

5 FOUNDATION DETAIL AT GARAGE
SCALE: NO SCALE

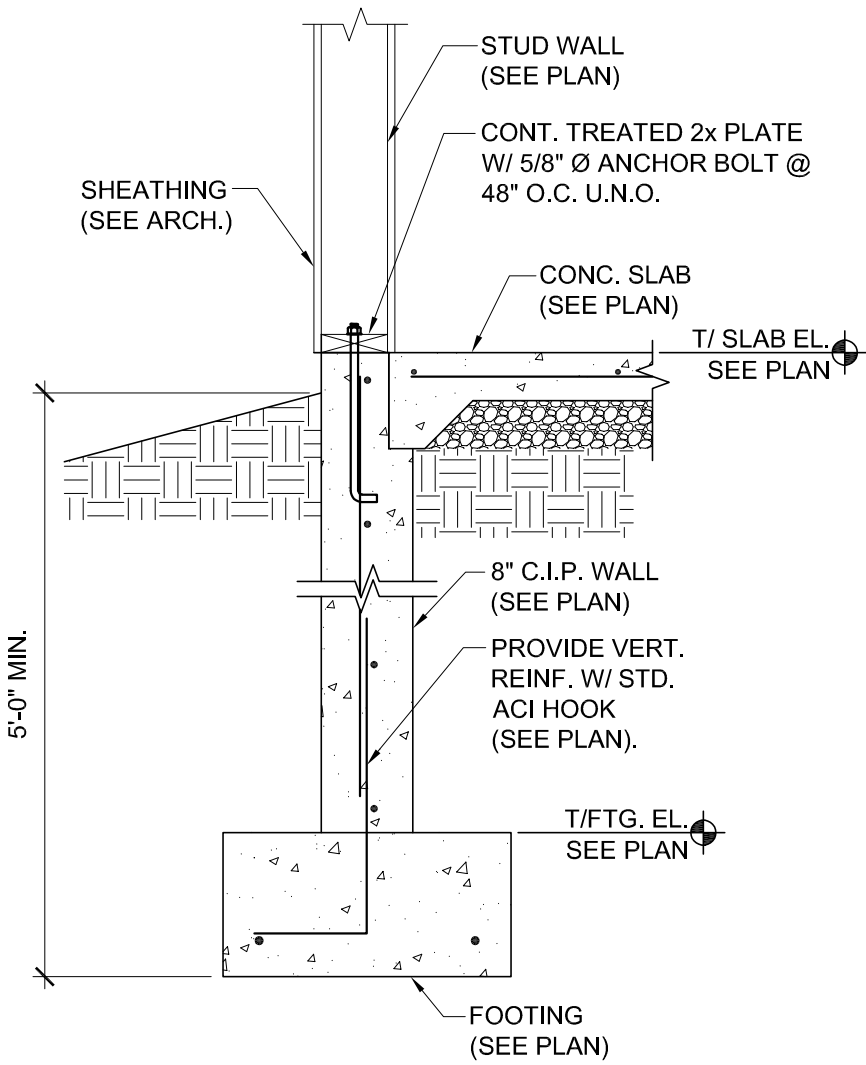

6 TYP. EXTERIOR WALL DETAIL
SCALE: NO SCALE

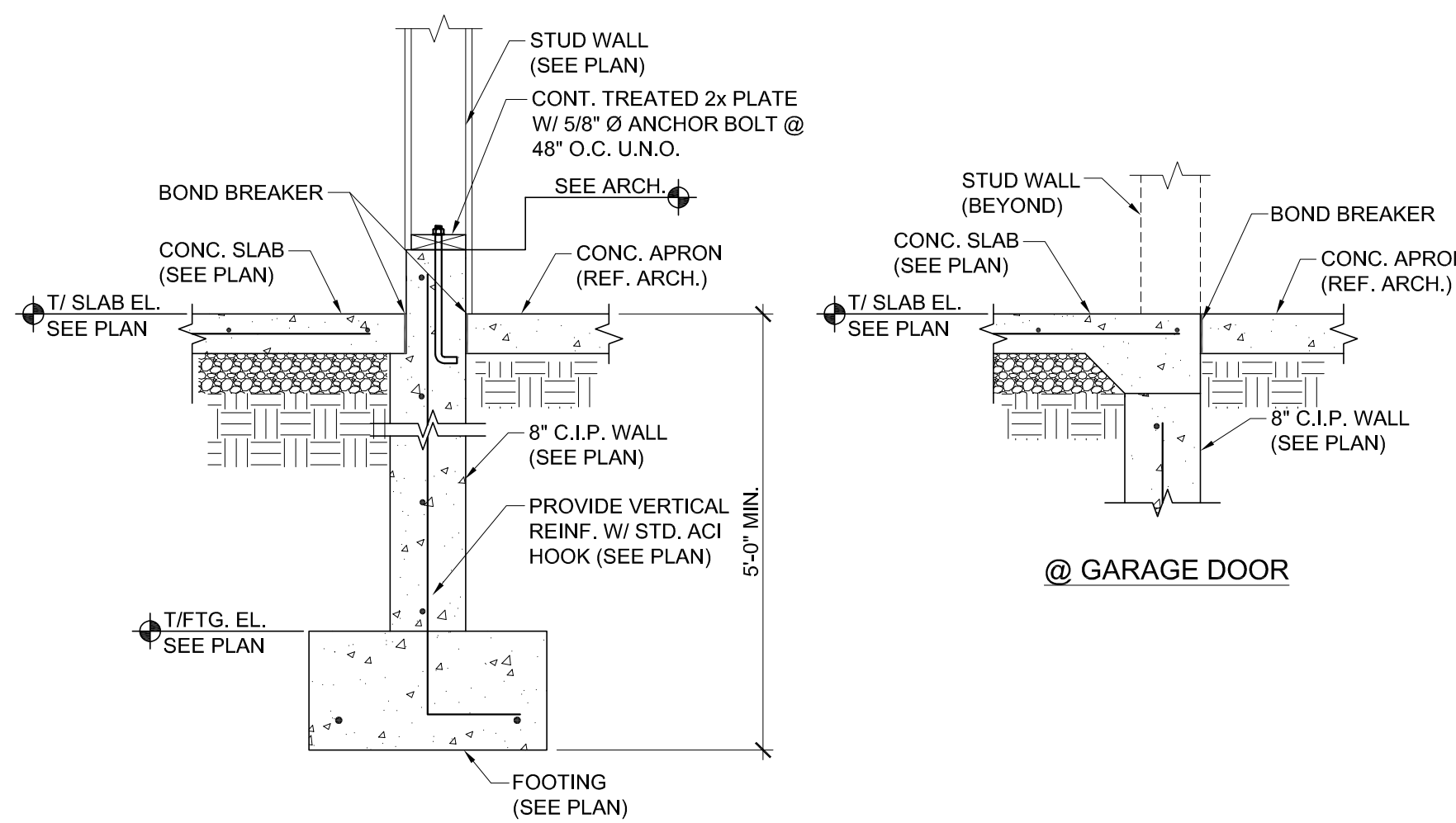

7 EXTERIOR WALL DETAIL @ GARAGE
SCALE: NO SCALE

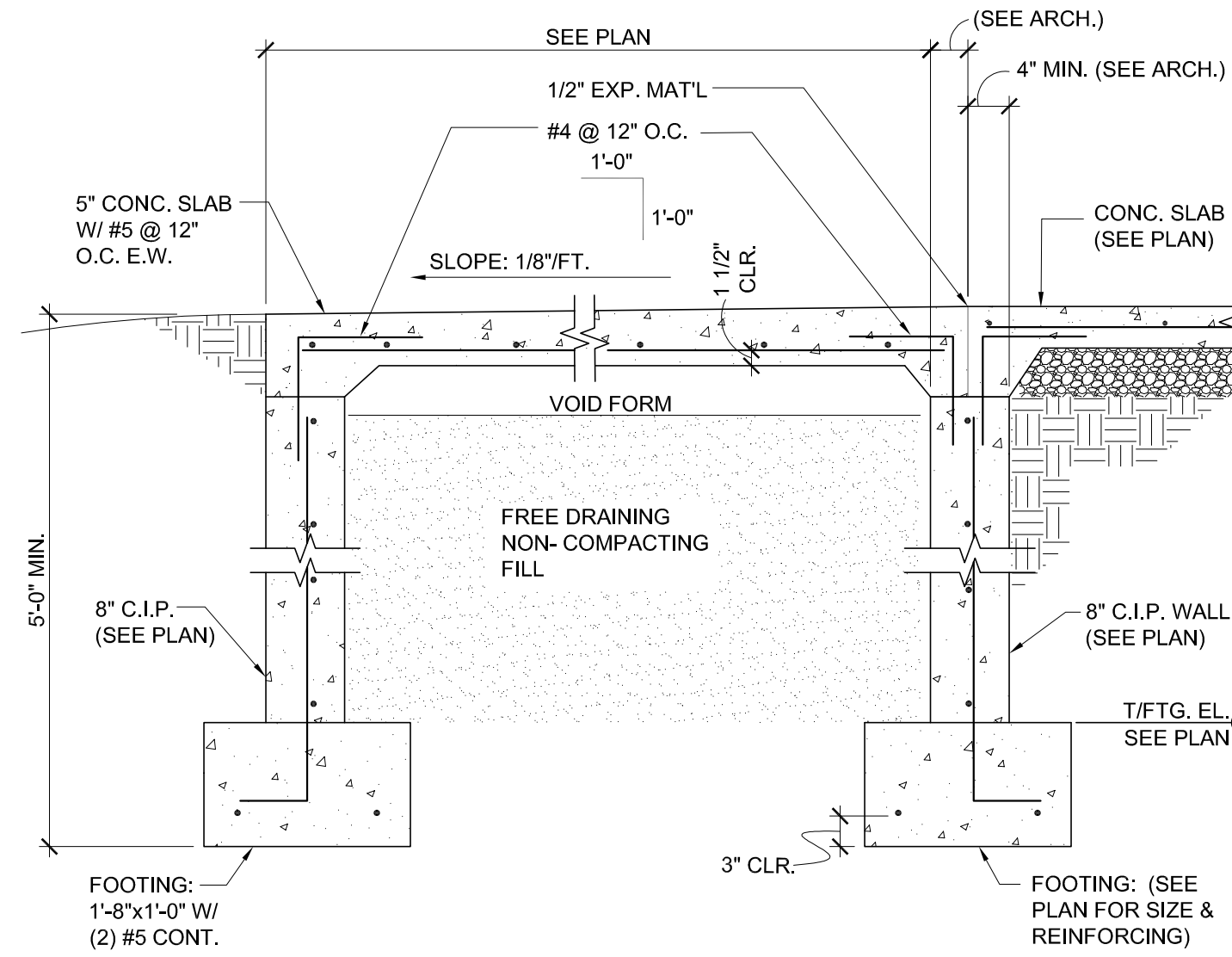

8 TYPICAL STOOP DETAIL
SCALE: NO SCALE

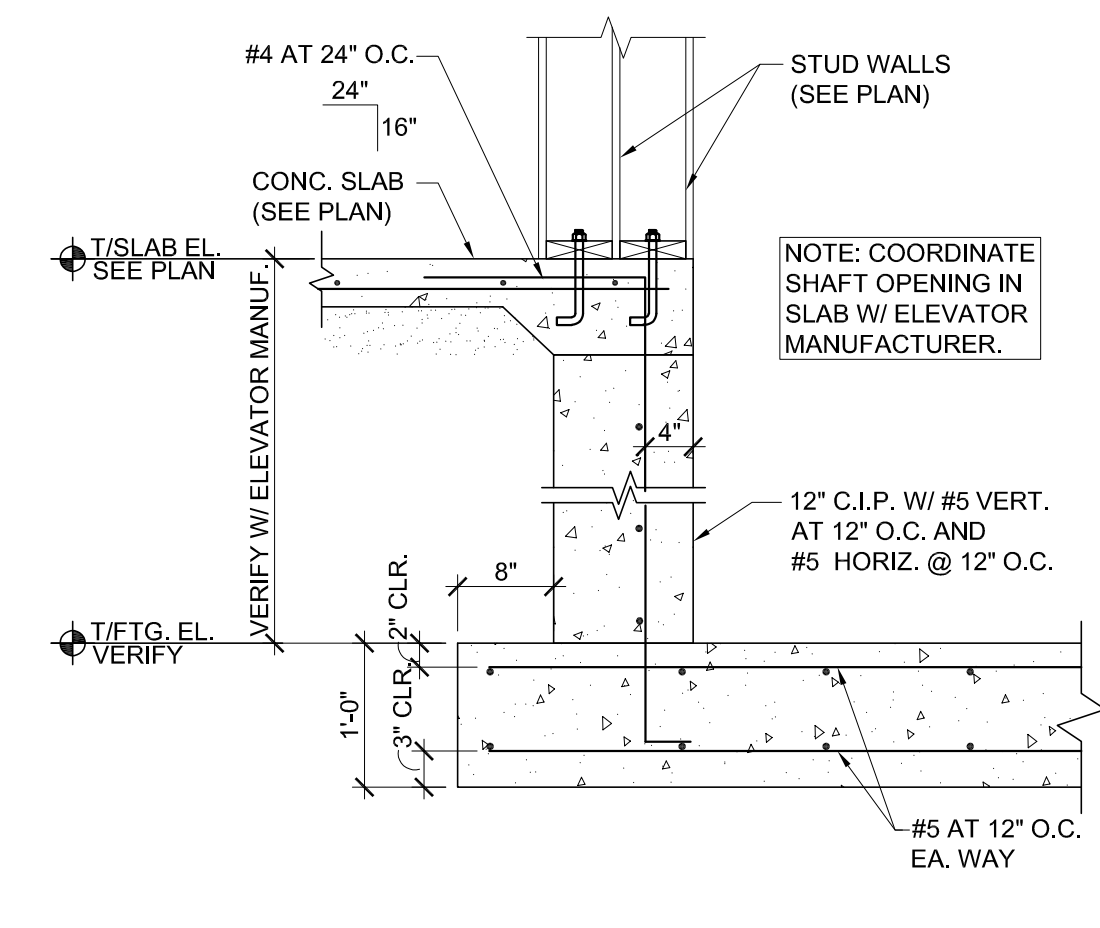

9 ELEVATOR PIT DETAIL
SCALE: NO SCALE

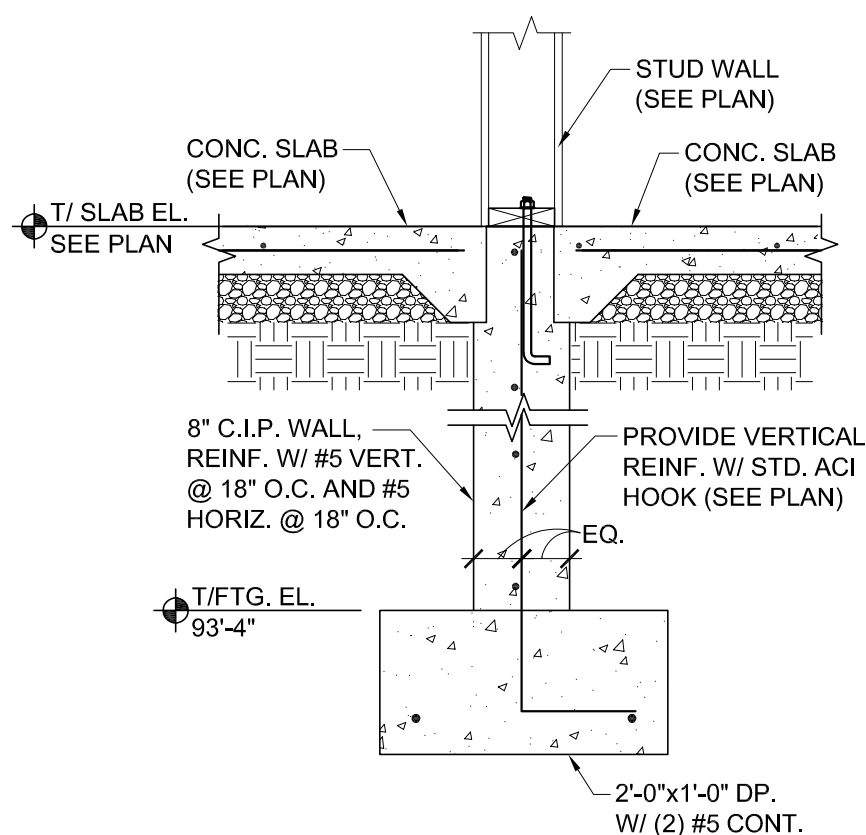

10 INTERIOR FTG. - ALT. FOR WINTER CONSTRUCTION
SCALE: NO SCALE

SEE 7/S501 FOR ADDL. INFO. FOR SHEAR WALL LOCATIONS

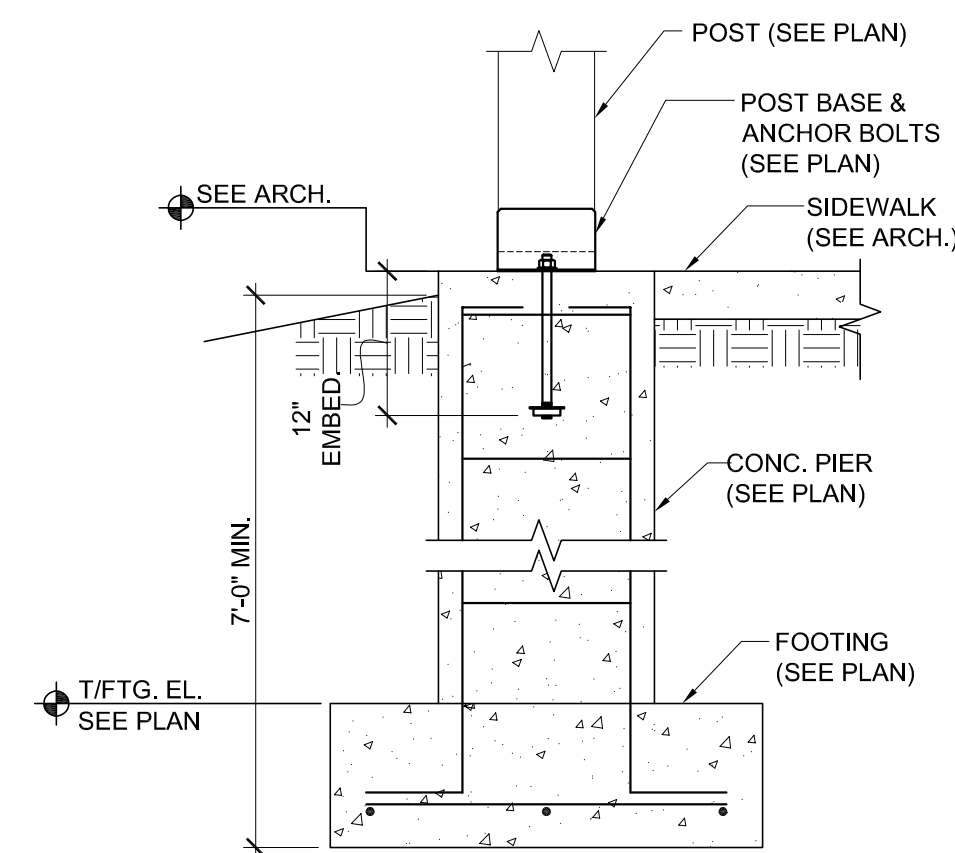

11 ENTRY POST DETAIL
SCALE: NO SCALE

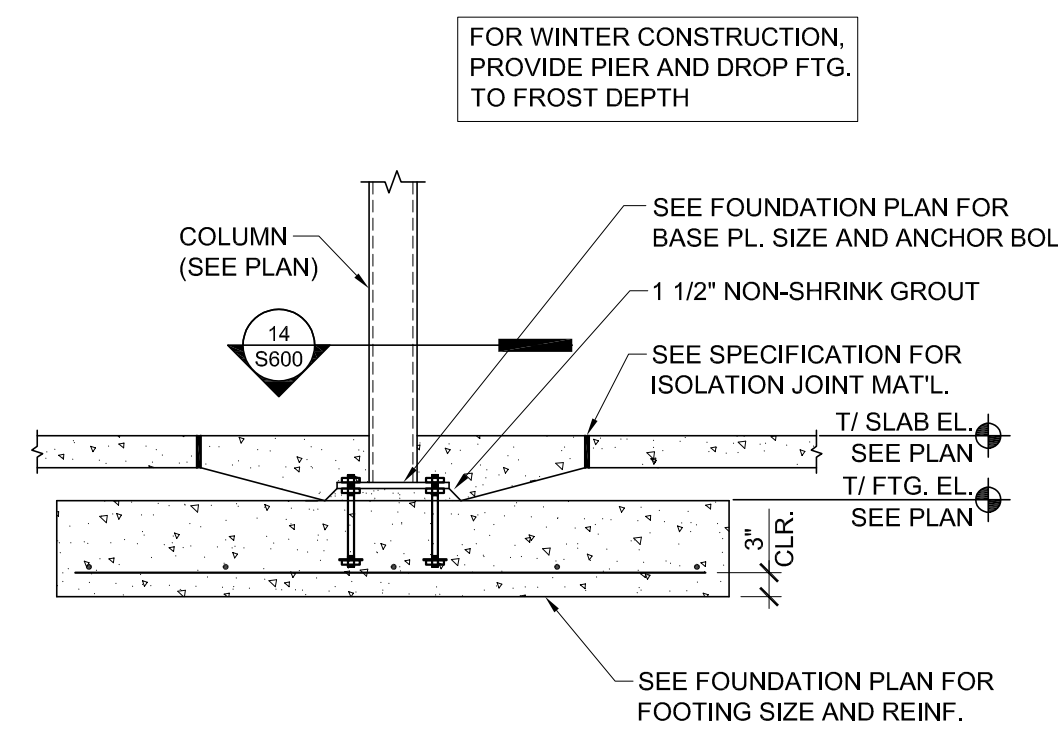

12 TYPICAL INTERIOR STEEL COL. FOOTING DETAIL
SCALE: NO SCALE

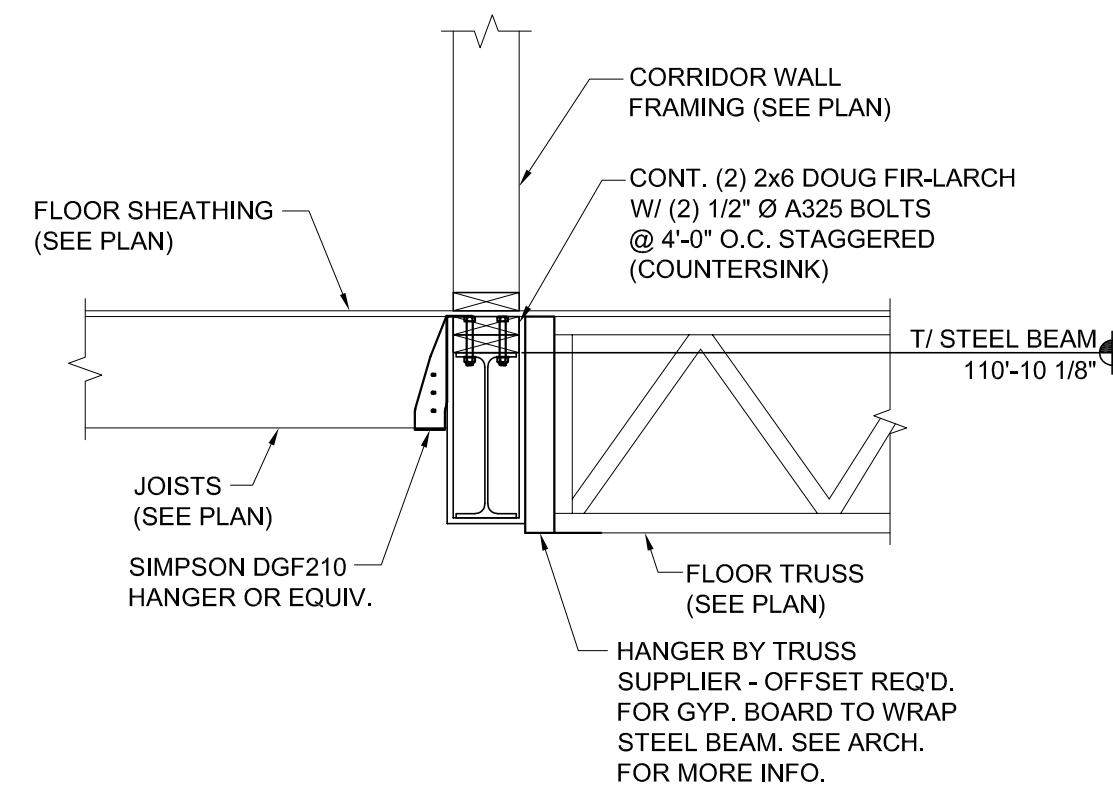

13 DETAIL AT STEEL BEAM
SCALE: NO SCALE

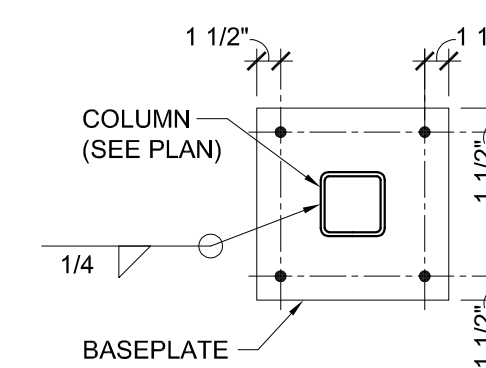

14 BASEPLATE DETAIL
SCALE: NO SCALE

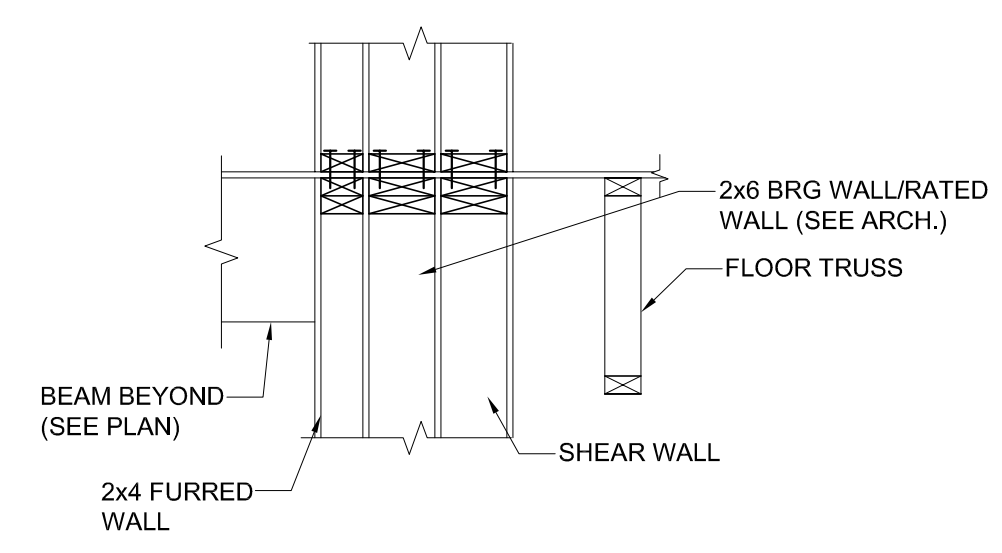

15 BEARING DETAIL @ FURRED WALL
SCALE: NO SCALE

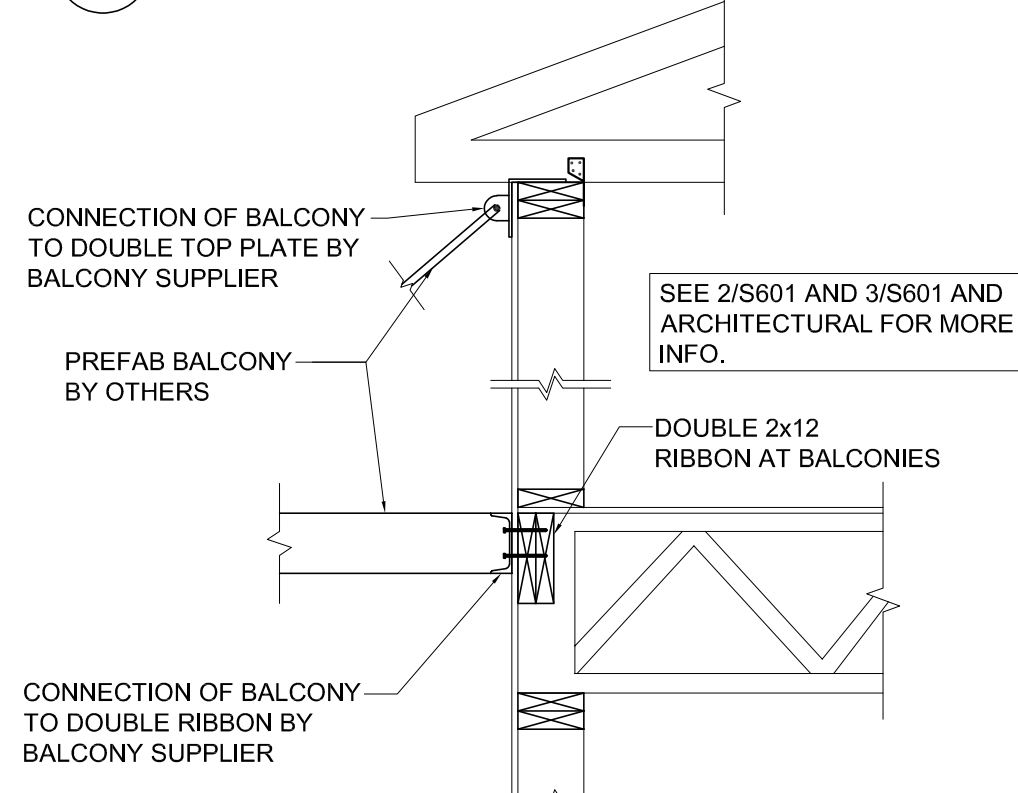

16 SECTION AT PRE-FAB BALCONIES
SCALE: NO SCALE

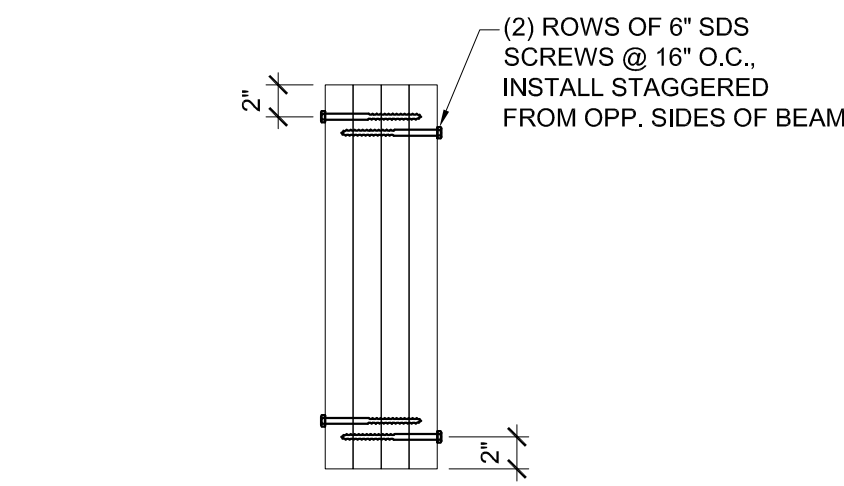

17 DETAIL
SCALE: NO SCALE

NO.	REVISION/ISSUE	DATE
2	MECHANICAL REVISIONS	10/07/25
1	REVISIONS	07/23/25
	PERMIT SET	03/06/25

JOB TITLE:
PARK & 3rd LOFTS

ALEXANDRIA, MN

Registration Information :
I hereby certify that this plan, specification or report was prepared by me or under my direct supervision and that I am a duly Licensed Engineer, under the laws of the State of Minnesota.

Signature: *[Signature]*
Name: JOSHUA HERZOG
Date: 07/23/25 Reg. No.: 42392

HERZOG ENGINEERING
1334 81ST AVE NE
SPRING LAKE PARK, MN 55432
(612) 844-1234
WWW.HERZOGENGINEERING.COM

SHEET CONTENTS:
DETAILS

PROJECT #: 251010
DRWN. BY: CL
CHKD. BY: JH
SCALE: AS NOTED

SHEET #:
S600